

# DTV700 Installation Quick Start Guide - Software Version 112

The Wegener Model DTV 700 Broadcast Digital Television Processor receives VHF/UHF broadcast HDTV signals and provides an output ASI stream for connection to a cable system QAM modulator. This guide provides information for setting up and operating the DTV700. Additional information may be found on the Wegener web site at [www.wegener.com/](http://www.wegener.com/)

In addition to this guide, your box should include:

1. DTV700 Broadcast Digital Television Processor
2. Power cord
3. UL safety sheet

## Front and Rear Panel View

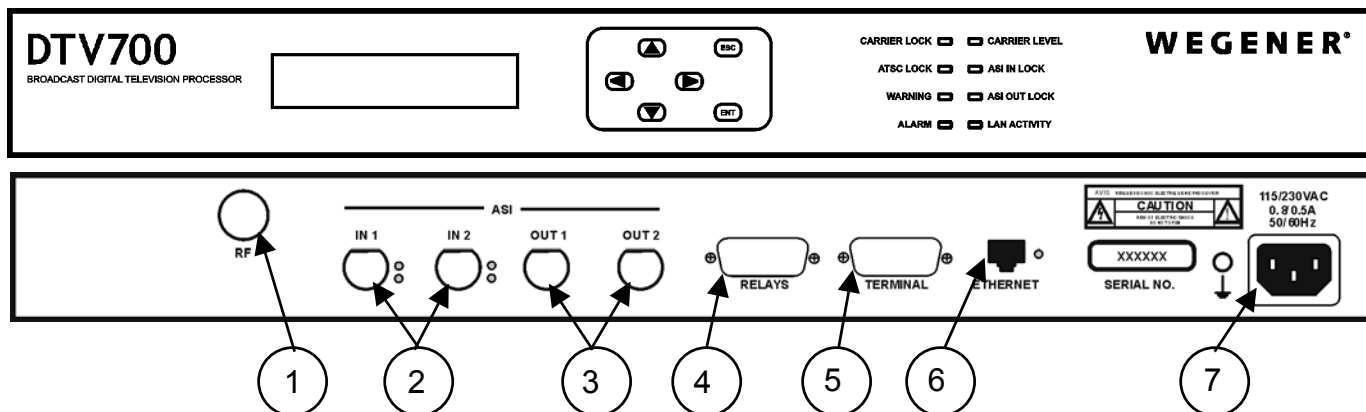

### Rear Panel Connector Descriptions

Ref	Connector Designation	Type	Signal Name	Description
1	RF Input	Type F	RF In	From VHF/UHF Antenna
2	ASI In 1 & 2	BNC	ASI In 1 & ASI In 2	From DTV700 Output or Other ASI Source
3	ASI Out 1 & 2	BNC	ASI Out 1 & ASI Out 2	To QAM Modulator, other DTV700, or ASI Mux
4	Status Relays	DB-9	Alarm, Warning, and Contact Closures	To Alarm Monitoring
5	Serial I/O	DB-9	RxD (output) & TxD (input)	To Local Terminal
6	Ethernet	RJ-45 jack	Ethernet_In & Out	To LAN
7	115/230 VAC	IEC receptacle	AC Line In	To AC Power Outlet

### Status Relays Signals (Ref 4)

Pin #	Signal Name
9	Alarm +
4	Alarm COM
8	Warning+
3	Warning COM
6	Not used
1	Not used
7	Not used
2	Not used

### LED Indicator Descriptions

LED	Description	LED	Description
<b>CARRIER LOCK</b>	<b>ON</b> - Tracking carrier <b>OFF</b> - No carrier	<b>CARRIER LEVEL</b>	<b>ON</b> - RF level is OK <b>FLASH</b> - RF level HIGH or LOW <b>OFF</b> - Not tracking RF carrier
<b>ATSC LOCK</b>	<b>ON</b> - ATSC input sync present <b>OFF</b> - No sync detected	<b>ASI IN LOCK</b>	<b>ON</b> - ASI input sync present <b>OFF</b> - No ASI sync.
<b>WARNING</b>	<b>ON</b> - Warning conditions <b>OFF</b> - No warnings	<b>ASI OUT LOCK</b>	<b>ON</b> - ASI output active <b>FLASH</b> - Output data overflow <b>OFF</b> - No ASI output
<b>ALARM</b>	<b>ON</b> - Alarm conditions <b>OFF</b> - No alarms	<b>LAN ACTIVITY</b>	<b>BLINKS</b> - LAN data present for this unit

### Program and PID Mapping

Program and PID mapping are performed in two ways depending on whether ASI input is turned off or turned on.

**ASI Input Turned Off:** This is an RF Input only mode. In this mode all programs received are output. All program number and PID assignments are passed to the output without change. If the user wishes to eliminate a program from the output, then the DTV700 must be placed in the ASI input turned on mode and disregard the warning that no ASI input is detected.

**ASI Input Turned On:** This is the multiplex mode, which combines the ASI input programs with the RF programs. In this mode all programs are turned off until selected by the user. A check box is provided on the Stream Info folder of the web interface to select programs for the output. A box is also provided for changing the program number. This allows the user to avoid duplicate program numbers from the RF and ASI inputs. The DTV700 automatically remaps the PID numbers to avoid duplicate PID assignments.

**PSIP Enable:** If PSIP Enable is turned on (web browser control), the MGT, STT, RRT, CVCT, and EIT-0 through EIT-3 are output for the combined RF and ASI inputs. ETT is not output. If PSIP Enable is turned off, no PSIP information is output.

**Note:** User program selection and mapping requires use of the Web Browser User Interface described later in this guide.

# Front-panel User Interface

Note that from any screen, pressing the ESC key twice will return you to the Home Screen.

## 1. Home Screen (alternates between screens every 4 seconds.)

First Screen

```
CHAN : 20
BDCAST          SNR : 32.1
```

Second Screen

```
551.00MHZ
8VSB          SNR : 32.1
```

Press the **▶** key to go to Input Setup (step 2).

Press the ENT key to view the unit's serial number and application software version number

## 7. Output Rate Selection

```
Output rate :
38.81 Mbps
```

Press the ENT key and then the **▲** or **▼** key to select 19.39 Mbps (8VSB), 26.97 Mbps (64QAM), or 38.81 Mbps (256QAM). Press the ENT key to confirm the selection.

Press the **▶** key to go to IP Setup (8).

Press the **◀** key to go to Input Setup (2).

Press the ESC key to go to the Home Screen (1).

## 2. Input Setup

```
Input Setup...
```

Press the ENT key to go to Channel Selection (3).

Press the **▶** key to go to Output Rate Select (7).

Press the ESC key to go to the Home Screen (1).

## 8. IP Setup

```
IP Setup...
```

Press the ENT key to go to IP Address Select (9).

Press the **◀** key to go to Output Rate Select (7).

Press the ESC key to go to the Home Screen (1).

## 3. Channel Selection

```
CHANNEL :
20
```

Press the ENT key and then the **▲** or **▼** key to change the selected channel number. Press the ENT key to confirm the selection.

Press the **▶** key to go to the RF Standard screen (4).

Press the ESC key to go to Input Setup (2).

## 9. IP Address Selection

```
IP Address :
000.000.000.000
```

Press the ENT key and then press the arrow keys to change the IP address. Press the ENT key to confirm the selection.

Press the **▶** key to go to the Netmask Select (10).

Press the ESC key to go to IP Setup (8).

## 4. RF Standard Selection

```
RF Standard :
BROADCAST
```

Press the ENT key and then the **▲** or **▼** key to select BROADCAST or CATV. Press the ENT key to confirm the selection.

Press the **▶** key to go to ASI Input Select (5).

Press the **◀** key to go to Channel Select (3).

Press the ESC key to go to Input Setup (2).

## 10. Netmask Selection

```
Netmask :
255.255.0.0
```

Press the ENT key and then press the arrow keys to change the Netmask. Press the ENT key to confirm the selection.

Press the **▶** key to go to Gateway Select (11).

Press the **◀** key to go to IP Address Select (9).

Press the ESC key to go to IP Setup (8).

## 5. ASI Selection

```
ASI Input :
ASI 1
```

Press the ENT key and then the **▲** or **▼** key to select ASI OFF, ASI 1, or ASI 2. Press the ENT key to confirm the selection.

Press the **▶** key to go to RF Input Enable (6).

Press the **◀** key to go to RF Standard (4).

Press the ESC key to go to Input Setup (2).

## 11. Gateway Selection

```
Gateway :
0.0.0.0
```

Press the ENT key and then press the arrow keys to change the Gateway. Press the ENT key to confirm the selection.

Press the **◀** key to go to Netmask Select (10).

Press the ESC key to go to IP Setup (8).

## 6. RF Input Enable Selection

```
RF Input :
ENABLED
```

Press the ENT key and then the **▲** or **▼** key to select ENABLED or DISABLED. Press the ENT key to confirm the selection.

Press the **◀** key to go to ASI Selection (5).

Press the ESC key to go to Input Setup (2).

## Web Browser User Interface

In addition to the front panel, the user may control and monitor the unit using the rear-panel Ethernet connection. Before using the Ethernet connection, the appropriate IP address, netmask, and gateway must be selected via the front-panel interface. There are two basic methods of using the Ethernet connection – with a directly connected PC or with a LAN connection.

### Locally connected PC –

Connect the DTV700 Ethernet connection to the Ethernet network connector on the PC using a crossover RJ-45 cable (8 pins).  
Set the DTV700 IP Setup as follows: IP Address: 172.016.100.020      Netmask: 255.255.000.000      Gateway: 000.000.000.000  
Set the PC IP address as follows:<sup>1</sup> IP Address: 172.016.100.001      Subnet Mask: 255.255.000.000  
Connect to the DTV700 using the web browser instructions below.

### LAN Connection –

Connect the DTV700 Ethernet connection to the LAN using a normal RJ-45 cable (8 pins). Set the DTV700 IP Address, Netmask, and Gateway as directed by your network administrator. Use any PC on the LAN to connect to the DTV700 using the web browser instructions below.

### Using the Web Browser –

Using the web browser of your choice, set the Address to <http://nnn.nnn.nnn.nnn> where nnn.nnn.nnn.nnn is the IP address of the unit to be controlled. Each unit on the network must have its unique address. You should see the screens below when connected to the unit. You may select the screen viewed by clicking on the [Control and Status](#), [Stream Information](#), and [Q&A](#) tabs.

The **Control and Status** screen below allows you to select the off-air channel number for the HDTV input. The status section provides signal status.

The screenshot shows the 'Control & Status' page of the DTV700 web interface. The header includes the 'DTV700 DIGITAL TELEVISION PROCESSOR' logo and the 'WEGENER' logo. Navigation tabs for 'Control & Status', 'Stream info', and 'Q & A / Help' are visible. The 'Control' section on the left contains: 'DTV700 SN: 16776960 Version 110', 'RF INPUT' with 'Channel: 27' and 'Tune' button, radio buttons for 'Broadcast' and 'Cable', 'ASI Input' with a dropdown set to 'ASI 1' and a 'Select' button, 'ASI Output' with a dropdown set to '38.81 Mbps' and a 'Select' button, and 'PSIP Enable' with a dropdown set to 'ON' and a 'Select' button. The 'Status' section on the right displays: 'Channel: 27', 'Tuner: Broadcast', 'Frame Lock: TRUE', 'SNR: 28.3', 'Errored Secs: 0', 'Signal Status: Very Strong', 'ASI Input: ASI 1, ASI Input Locked', and 'ASI Output: 38.81 Mbps (256QAM), ASI Output Locked'.

The **Stream Information** screen below shows input and output status. The input side allows you to select the program streams that you wish to be included in the output. This is done by clicking on or off the program check box and clicking on the Update Selected Programs bar.

The screenshot shows the 'Stream info' page of the DTV700 web interface. The header is identical to the previous screen. Navigation tabs for 'Control & Status', 'Stream info', and 'Q & A / Help' are visible. The 'RF Input:' section on the left lists: 'WAGA-HD [5-1]' with 'Program 2 (0020) ==> Program: 2' and sub-items 'Video (0021)' and 'AC-3 Audio (0024)'; and 'WAGA-SD [5-2]' with 'Program 3 (0030) ==> Program: 100' and sub-items 'Video (0031)' and 'AC-3 Audio (0034)'. The 'ASI Input:' section lists: 'WTBS HD [17-1]' with 'Program 2 (0020) ==> Program: 3' and sub-items 'Video (0021)' and 'AC-3 Audio (0024)'. At the bottom left are buttons for 'Update Selected Programs' and 'Uncheck All'. The 'ASI Output:' section on the right lists: 'HDNET 1 [60-1]' with 'Program 3 (0020) (PCR 21) ASI-2' and sub-items 'Video (0021)' and 'AC-3 Audio (0024)'.

<sup>1</sup> To change the PC IP address, go to the Settings, Control Panel and double click on the Network icon. Select Configuration, TCP/IP protocol, and click on the Properties box. Click on Specify IP Address and set the IP Address and Subnet Mask as indicated. Click OK to restart the PC with the new values.  
800007-02 Rev. C

### Basic System – One HDTV to ASI output

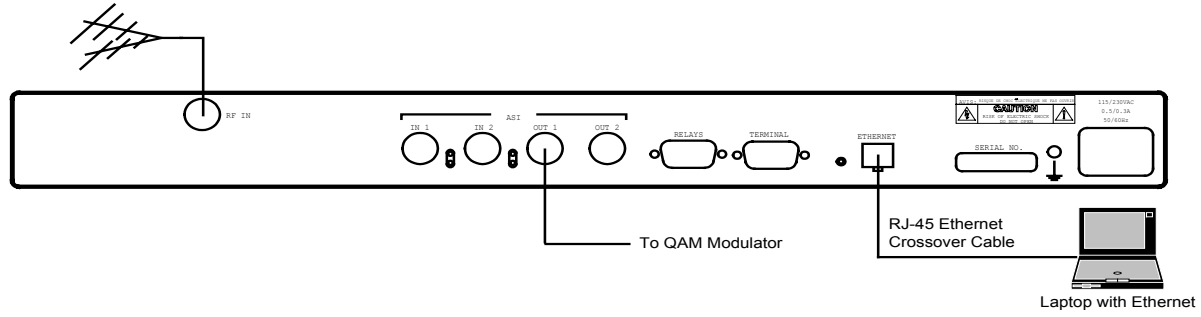

### Basic Multiplex System – Two HDTVs multiplexed to ASI output

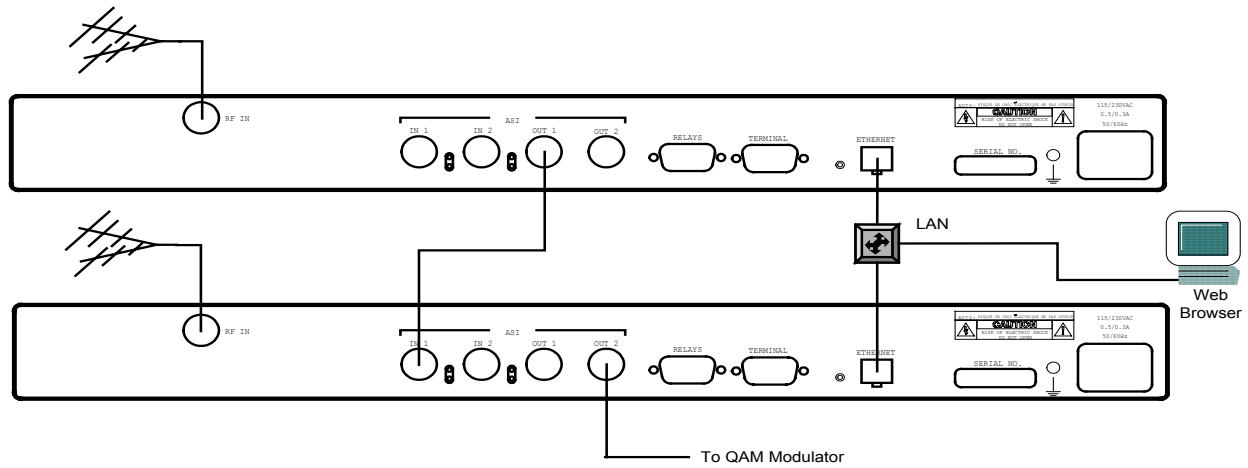

### Full Multiplex System – Two HDTVs plus satellite channels multiplexed to ASI output

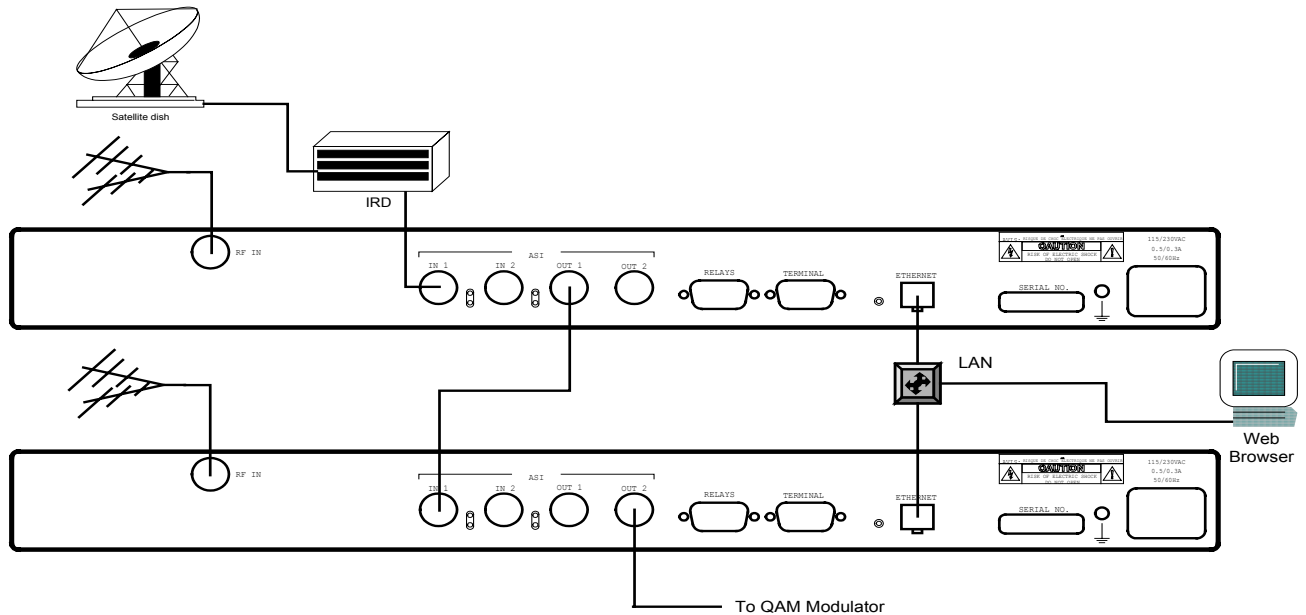

## Environmental Operating Conditions & Physical Specifications

Use	Indoor
Altitude	Up to 2000 meters
Temperature Range	10° C to 40° C
Relative Humidity (max.)	80% for temperatures up to 31° C decreasing linearly to 50% relative humidity as 40° C.
Weight	10.6 pounds or 4.81 kilograms
Dimensions (H x W x D)	3.5"x 19"x 10.5" or 88.9 mm x 482.6 mm x 266.7 mm
Input Power Rating	90-132Vac & 175-264Vac, 43 Watt, 50/60 Hz

### Elevated Operating Ambient

If equipment is installed in a closed or multi-unit rack assembly, the operating ambient of the rack may be greater than the room ambient. Therefore, considerations should be given to the TMRA, or Temperature inside the Mounting Rack, and not just inside the room.

### Reduced Air Flow

Installation of the equipment in a rack should be such that the amount of airflow required for safe operation of the equipment is not compromised.

### Mechanical Loading

Mounting of equipment in a rack should be such that a hazardous condition is not achieved due to uneven loading. This unit is not very heavy, but total rack loading should be considered.

### Circuit Overloading

Consideration should be given to the connection of the equipment to the supply circuit and the effect that overloading of circuits could have on over-current protection and supply wiring. Appropriate consideration of equipment nameplate ratings should be used when addressing this concern.

### Reliable Earthing

Reliable earthing of rack-mounted equipment should be maintained. Particular attention should be given to supply connections other than direct connection to the Branch (use of power strips).

### Desktop Installation

To set up the DTV700 in a desktop environment, place it on a flat surface where it will not be subject to being hit or pushed, and will not have anything spilled or dropped on it. Also, the cables connected to the unit should be routed so they are not hit or pulled, which might cause damage to the connectors or to the unit itself. Additionally, there should be sufficient flow of cool air so the unit stays within its operating parameters.

### Rack Installation

When installed in an equipment rack, it is best that the DTV700 be supported by angle brackets or cross supports. These should be screwed or bolted securely to the equipment rack, and be capable of supporting the unit and its connecting cables. Do NOT install the unit if you have doubts about the unit being safely supported. There are also 4 holes in the front brackets, which are designed to accept screws for further anchoring. It is also essential that these brackets be used so the unit cannot be moved forward and fall from the rack. It is **always** best to install the angle brackets or cross-members before setting the unit in place. Then, prior to installing cables, put anchored screws or bolts-and-nuts into place on the front brackets. Failure to do this can lead to pushing the unit out the front of the rack in later steps.

### Warranty

The following warranty applies to all Wegener Communications products. All Wegener Communications products are warranted against defective materials and workmanship for a period of one year after shipment to customer. Wegener Communications' obligation under this warranty is limited to repairing or, at Wegener Communications' option, replacing parts, subassemblies, or entire assemblies. Wegener Communications shall not be liable for any special, indirect, or consequential damages. This warranty does not cover parts or equipment, which have been subject to misuse, negligence, or accident by the customer during use. All shipping costs for warranty repairs shall be prepaid by the customer. There are no other warranties, express or implied, except as stated herein.

### Technical Support

In the event the unit fails to perform as described, contact Wegener Communications Customer Service at (770) 814-4057, FAX (678) 624-0294, or E-mail "[service@wegener.com](mailto:service@wegener.com)".

Corporate Office  
Wegener  
11350 Technology Circle  
Duluth, GA 30097

Service Department  
Wegener  
359 Curie Drive  
Alpharetta, GA 30005

**W E G E N E R<sup>®</sup>**  
Advanced Digital Technologies